

GMS 10.0 Tutorial

SEEP2D – Earth Dam

Use SEEP2D to compute seepage through an earth dam

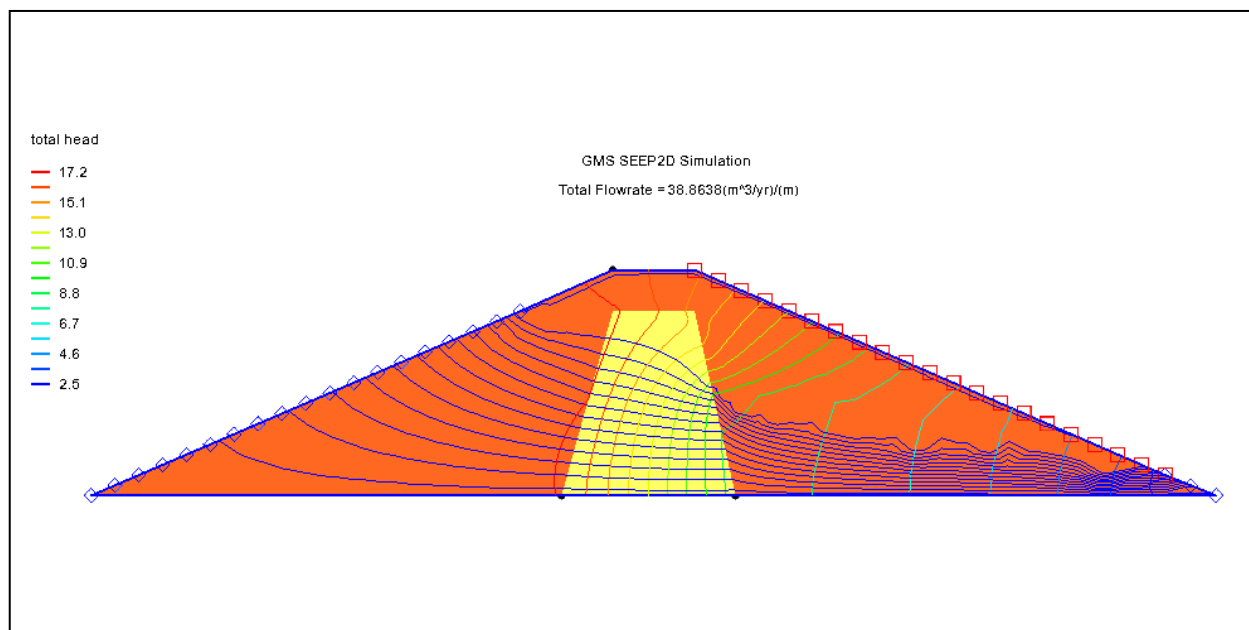

Objectives

Use the SEEP2D interface in GMS to compute seepage through an earth dam. Use different material properties for the shell and core of the dam. Use the exit-face boundary condition on the downstream slope.

Prerequisite Tutorials

- Feature Objects

Required Components

- GIS
- Map Module
- Mesh Module
- SEEP2D

Time

- 25–40 minutes



1	Introduction	2
1.1	Outline.....	2
2	Description of Problem	2
3	Program Mode	3
4	Getting Started	3
5	Setting the Units	4
6	Saving the Project	4
7	Creating the Conceptual Model Features	5
7.1	Defining a Coordinate System.....	5
7.2	Creating the Corner Points.....	5
7.3	Creating the Arcs.....	6
7.4	Creating the Polygons.....	7
7.5	Assigning the Material Properties and Zones.....	7
8	Assigning Boundary Conditions	8
8.1	Specified Head Boundary Conditions.....	8
8.2	Exit Face Boundary Conditions.....	9
8.3	Building the Finite Element Mesh.....	9
9	Setting the Analysis Options	11
10	Running SEEP2D	11
11	Viewing the Solution	11
12	Conclusion	12

1 Introduction

This tutorial describes the steps involved in performing a SEEP2D simulation for an earth dam with an unsaturated zone.

1.1 Outline

Here are the steps to the tutorial:

1. Create a SEEP2D conceptual model.
2. Map the model to a 2D mesh.
3. Define conditions for both a saturated and unsaturated zone.
4. Convert the model to SEEP2D and run SEEP2D.

2 Description of Problem

The problem in this tutorial is shown in Figure 1. The problem consists of an earth dam with anisotropic soil and a low permeability core in the interior.

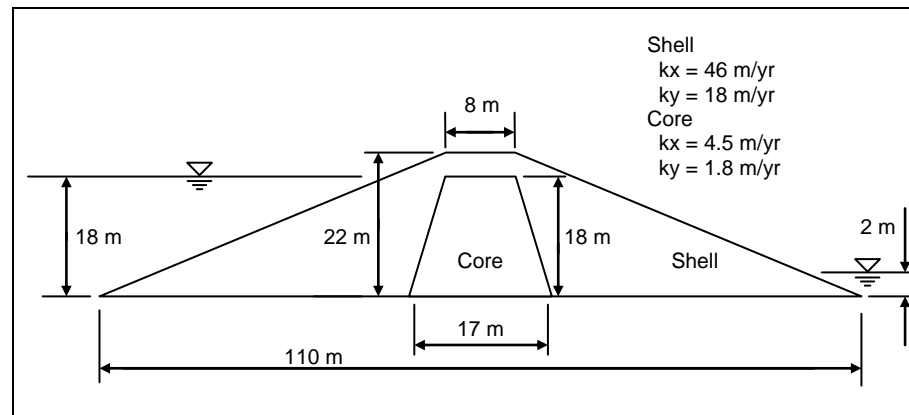

Figure 1 Earth dam problem

3 Program Mode

The GMS interface can be modified by selecting a *Program Mode*. When the user first installs and run GMS it is in the standard or “GMS” mode which provides access to the complete GMS interface, including all of the MODFLOW tools. The “GMS 2D” mode provides a greatly simplified interface to the SEEP2D and UTEXAS codes. This mode hides all of the tools and menu commands not related to SEEP2D and UTEXAS. This tutorial assumes that the user is operating in the GMS 2D mode. Once the mode is changed, the user can exit and restart GMS repeatedly and the interface stays in the same mode until the user changes it back. Thus, the user only needs to change the mode once if the user intends to repeatedly solve SEEP2D/UTEXAS problems. If the user is already in GMS 2D mode, skip ahead to the next section. If the user is not already in GMS 2D mode, do the following:

1. Launch GMS.
2. Select the *Edit / Preferences* command.
3. Select the *Program Mode* option on the left side of the dialog.
4. On the right side of the dialog, change the mode to “GMS 2D.”
5. Click on the **OK** button.
6. Click **Yes** in response to the warning.
7. Click **OK** to get rid of the *New Project* dialog.
8. Then select the *File / Exit* command to exit GMS.

4 Getting Started

Do the following to get started:

1. If necessary, launch GMS.
2. If GMS is already running, select the *File / New* command to ensure that the program settings are restored to their default state.

At this point, the user should see the *New Project* dialog. This dialog is used to set up a GMS conceptual model. A conceptual model is organized into a set of layers or groups called “coverages.” GMS 2D allows the user to quickly and easily define all of the coverages needed for the conceptual model using the *New Project* dialog. Most of the options the user will see in the window are related to UTEXAS. For SEEP2D models, the only coverage needed is the *Profile lines* coverage. This allows the user to define the geometry of the mesh, the boundary conditions, and the material zones.

3. Change the *Conceptual model name* to “Earth Dam Model.”
4. Turn off the *UTEXAS* option in the *Numerical models* section.
5. Make sure the *Profile lines* option is still selected.
6. Click **OK**.

The user should see a new conceptual model object appear in the Project Explorer.

5 Setting the Units

Before the user continues, it is necessary to establish the units to be used. GMS will display the appropriate units label next to each of the input fields to remind the user to be sure to use consistent units.

1. Select the *Edit | Units* command to open the *Units* dialog.
2. For the length select the “...” button, Change the units for both vertical and horizontal to “meters.”
3. Select “yr” for the *Time* units.
4. Select “kg” for the *Mass* units.
5. Select “N” for the *Force* units.
6. Select the **OK** button.

6 Saving the Project

Before continuing, save the project to a GMS project file.

1. Select the *File / Save As* command.

2. Navigate to the `\Tutorials\SEEP2D` directory.
3. Change the name of the project file to “s2uncon.”
4. Click on the **Save** button.

Click on the **Save**  macro frequently to save all changes.

7 Creating the Conceptual Model Features

The first step in setting up the problem is to create the GIS features defining the problem geometry. The user will begin by entering a set of points corresponding to the key locations in the geometry. The user will then connect the points with lines called “arcs” to define the outline of the problem. The user will then convert the arcs to a closed polygon defining the problem domain. Once this is complete, the arcs and the polygon will be used to build the finite element mesh and define the boundary conditions to the problem.

7.1 Defining a Coordinate System

Before constructing the conceptual model features, the user must first establish a coordinate system. The user will use a coordinate system with the origin at the lower left corner of the dam as shown in Figure 2.

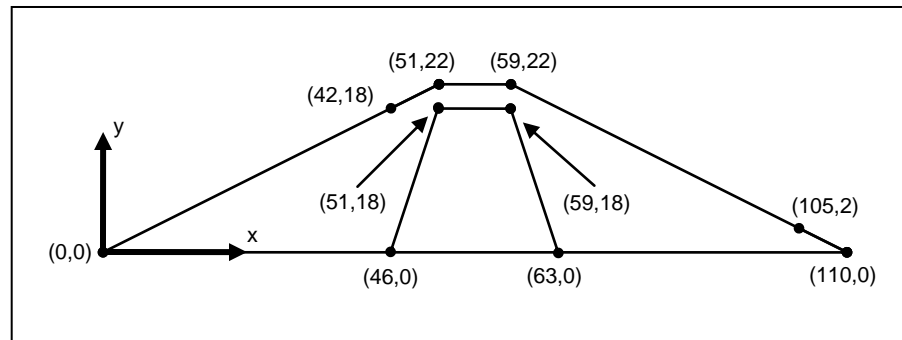



Figure 2 Coordinate system

7.2 Creating the Corner Points

The user is now ready to create some points at key corner locations. These points will then be used to guide the construction of a set of arcs defining the model boundary. The user can create points one at a time using the **Create Points**  tool, but it is usually easier to enter the point coordinates in a spreadsheet.

1. Right-click on the “Profile lines” coverage in the Project Explorer.
2. Select the **Attribute Table** command to open the *Attribute Table* dialog.

- Enter the following coordinates in the spreadsheet.

X	Y
0	0
59	22
110	0
42	18
51	22
51	18
59	18
46	0
63	0
105	2

- Click **OK** to exit the dialog.
- Now select the **Frame**  macro to center the view on the new points.

If the user needs to edit the node coordinates, this can be done by using the **Select Points/Nodes**  tool. When this tool is active, the user can select points and change the coordinates using the edit fields. The user can also select points and delete them using the *Delete* key on the keyboard or the *Delete* command in the *Edit* menu.

The nodes the user has created should resemble the nodes shown in Figure 3 (without the labels).

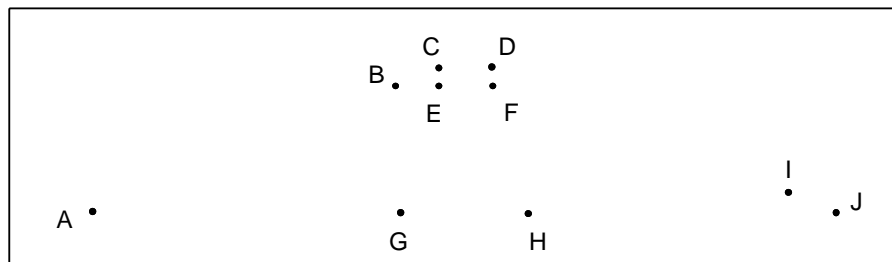



Figure 3 Points created in the profile lines coverage

7.3 Creating the Arcs

Now that the corner nodes are created, the next step is to create the arcs defining the boundaries of both the shell and the core of the dam. This can be accomplished as follows:

- Click on the *Profile lines* coverage to make sure it is active.
- Select the **Create Arc**  tool.
- Create a connected series of arcs around the perimeter of the dam by clicking on the following points in order: A-B-C-D-I-J-H-G-A.

4. Create the remaining arcs around the core boundary by clicking on the following points in order: G-E-F-H.

7.4 Creating the Polygons

Now that the arcs are created, the user can use the arcs to build polygons representing the regions enclosed by the arcs. The user will use the polygons to assign the material zones. To build the polygon, do the following:

1. Select the *Feature Objects* / **Build Polygons** command.



The user should see the polygons appear in the background.

7.5 Assigning the Material Properties and Zones

Next, the user will assign the material properties and zones. First, the user will create a material for each of the two zones in the problem and give each material a unique name, color, and set of hydraulic properties.

1. Click on the **Materials**  icon at the top of the GMS window.
2. Make sure the *SEEP2D* tab is selected.

Note that there is already one material. The user will use this material to represent the shell and create a new material for the core.

3. Change the name of the material from “material_1” to “Shell.”
4. Use the color picker to change the color to light orange .
5. Enter a value of “46” for $k1$.
6. Enter “18” for $k2$.
7. Enter “-0.3” for *Sat/Unsat linear front ho*.
8. Enter “0.001” for *Sat Unsat linear front kro*.
9. Create a new material by typing “Core” in the *Name* column of the blank row at the bottom of the spreadsheet.
10. Use the color picker to change the color to pale green .
11. Enter a value of “4.6” for $k1$.
12. Enter “1.8” for $k2$.
13. Enter “-1.2” for *Sat/Unsat linear front ho*.

14. Enter “0.001” for *Sat Unsat linear front kro*.
15. Click **OK**.

Note that both polygons are currently associated with the “Shell” material. The user will change the material assigned to the core polygon to the new “Core” material.

16. Choose the **Select Polygons**  tool.
17. Double-click anywhere inside the polygon representing the core of the dam.
18. Change the material to “Core.”
19. Select the **OK** button.
20. Click anywhere on the *Graphics Window* to unselect the polygon.

8 Assigning Boundary Conditions

The next step in defining the model is to assign boundary conditions to the conceptual model. For the problem being modeled, there are three types of boundary conditions: (1) no-flow boundary (flow is parallel to the boundary), (2) specified-head boundary, and (3) exit-face boundary. Boundaries without an explicit condition are no flow by default.

8.1 Specified-Head Boundary Conditions

The specified-head boundary conditions for the mesh are shown in Figure 4.

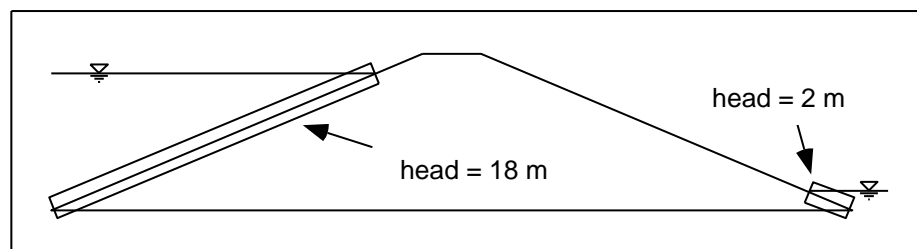



Figure 4 The specified-head boundary conditions

To enter the specified-head boundary conditions for the region on the left:

1. Choose the **Select Arcs**  tool.
2. Double-click on the arc on the left face of the embankment to open the *Attribute Table* dialog.
3. Change the *Type* to “head.”
4. Enter “18.0” in the *Head* field.

5. Select the **OK** button.
6. Repeat this process with the arc on the right side of the model and enter “2.0” in the *Head* field.

8.2 Exit-Face Boundary Conditions

The remaining boundary condition is an exit face. Since the user is modeling an unconfined condition, SEEP2D will iterate to find the location of the phreatic surface. To guide the iteration process, the user needs to mark all of the nodes on the mesh where the phreatic surface may exit as exit-face nodes (Figure 5).

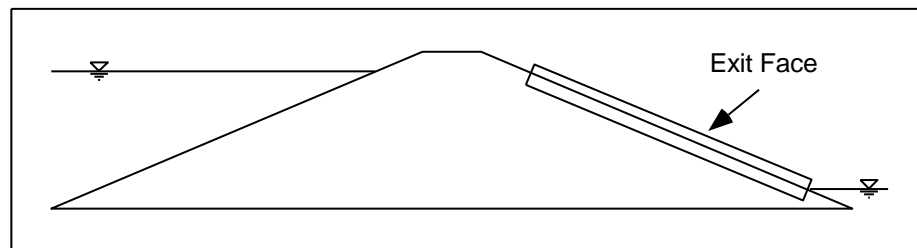



Figure 5 The exit-face boundary condition

Do the following to define the exit-face boundary conditions:

1. Choose the **Select Arcs**  tool.
2. Double-click on the arc on the upper right face of the embankment. Change the *Type* to “exit face.”
3. Click **OK** to exit the dialog.
4. Click anywhere in the blank part of the window to unselect the arc.

8.3 Building the Finite Element Mesh



It is now possible to build the finite element mesh used by SEEP2D. The mesh is automatically constructed from arcs and polygons in the conceptual model. The arcs are composed of both nodes and vertices. The nodes are the two end points of the arc. The vertices are intermediate points between the nodes. The gaps between vertices are called edges. At this point, all of the arcs have one edge and zero vertices. When the user issues the **Map** → **2D Mesh** command, the density of the elements in the interior of the mesh is controlled by the edge spacing along the arcs. Thus, the user will subdivide the arcs to create appropriately sized edges.

1. Choose the **Select Arcs**  tool.
2. Select all of the arcs by dragging a box that encloses all of the arcs.
3. Select the *Feature Objects* / **Redistribute Vertices** command.

4. Select the *Specified Spacing* option.
5. Enter a value of “2.5” for the *Average spacing*.
6. Select the **OK** button.
7. Switch to the **Select Vertices**  tool.

Notice the vertex spacing. The vertices are turned off by default but become visible when the **Select Vertices** tool is active. The user can also turn them on in the display options so they are always visible.

In this particular problem, most of the head loss will occur in the core of the dam. To more accurately model the core, the user will make the mesh denser in the core of the dam.

8. Switch back to the **Select Arcs**  tool.
9. Select the arcs that make up the core of the dam (G-E, E-F, F-H, H-G). Hold down the shift key to select multiple arcs at once or drag a box around the core.
10. Select the *Feature Objects* / **Redistribute Vertices** command.
11. Select the *Specified Spacing* option.
12. Enter a value of “1.0” for the *Average spacing*.
13. Select the **OK** button.
14. Switch to the **Select Vertices**  tool.

At this point, it is possible to construct the mesh.

21. Select the **Map → 2D Mesh**  macro at the top of the GMS window (or select the *Feature Objects* / **Map → 2D Mesh** command).

The user should now see a 2D mesh.

Finally, the user will convert the conceptual model to the SEEP2D numerical model. This will assign all of the boundary conditions defined on the feature objects to the node-based boundary conditions required by SEEP2D.

22. Select the **Map → SEEP2D**  macro at the top of the GMS window (or select the *Feature Objects* / **Map → SEEP2D** command).

A set of blue and red symbols should appear indicating that the boundary conditions have been assigned.

9 Setting the Analysis Options

Before running the model, the user needs to adjust the analysis options.



1. Save the model by clicking the **Save**  macro.
2. Select the *SEEP2D* | **Analysis Options** command to open the *SEEP2D Analysis Options* dialog.
3. Update the value of the *Unit weight of water* to be “9810.0” (the current units are N/m³).

Two methods are provided in SEEP2D for computing the relative conductivity in the unsaturated zone: the linear front method and the Van Genuchten method. With the linear front method, the relative conductivity varies linearly from the saturated value down to a user-specified minimum at a given negative pressure head. With the Van Genuchten method, the Van Genuchten parameters are used to define the variation of the relative conductivity in the unsaturated zone. Both methods are described in detail in the *SEEP2D Primer*. The user will use the linear front option.

4. Make sure the *Saturated/Unsaturated with linear front* option is selected.
5. Select the **OK** button to exit the dialog.

10 Running SEEP2D

It is now possible to save and run SEEP2D. Before running SEEP2D, make sure all of the changes have been saved to disk:

1. Select the **Save**  macro at the top of the GMS window (or select the *File* | **Save** command).
2. Select the **Run SEEP2D**  macro (or select the *SEEP2D* | **Run SEEP2D** command). At this point, SEEP2D is launched in a new window.
3. When the solution is finished, select the **Close** button.

GMS will automatically read in the SEEP2D solution when this dialog is closed.



11 Viewing the Solution

The user should now see a plot of the flow net. To better view the flow net, the user will turn off the display of nodes and elements.

1. Select the **Display Options**  button.
2. Select the *2D Mesh Data*  item from the list on the left.

3. Turn off the *Nodes* and *Element edges* options.
4. Turn on the *Mesh boundary* option.
5. Select the **OK** button.

Note that there are only a small number of flow lines. GMS determines the number of flow lines to display based on how closely spaced the equipotential lines are in one of the materials. By default, the interval is computed based on the Shell material. To base the number of flow lines on the Core material, do the following:

6. Select the **Display Options**  button.
7. Select the *2D Mesh Data*  item.
8. Select the *SEEP2D* tab.
9. In the *Base Material* pull-down list, make sure that “Core” material is selected.
10. Verify that the *Phreatic surface* option is turned on.
11. Select the **OK** button.

The user should now see flow lines through the model as well as the phreatic surface.

12 Conclusion

This concludes the tutorial. Here are the key concepts in this tutorial:

- SEEP2D can perform 2D unconfined flow modeling.
- SEEP2D problems can be set up quickly and easily using the conceptual model approach.
- The user can display a flow net and the phreatic surface in GMS.